



CORE CABLE CAGE

ASSEMBLY GUIDE



IMPORTANT - READ FIRST

Resistance training, gymnastics training and activities at height are potentially dangerous and may lead to severe injury or even death. This equipment must only be used by competent and responsible persons, or under the direct and visual control of a competent and responsible person. Use common sense when training, obtain instruction to ensure safe execution of movements.

Obtaining instruction in appropriate techniques and methods of use is your own responsibility. You assume all risks and responsibilities for all damage injury or death which may occur during or following incorrect use of this equipment in any matter whatsoever. AlphaFit bears no liability beyond the replacement value of the equipment in question.

It is the responsibility of the owner to ensure that all users of this product are adequately informed of all precautions. The safety and integrity designed into the equipment can only be maintained when it is regularly examined for damage and repaired. It is the responsibility of the user/owner to ensure that regular maintenance is performed. Inspect and properly tighten all parts regularly. Replace any worn or damaged parts immediately and do not use until the equipment has been repaired.

Both AlphaFit and buyer disclaim any express or implied warranty, including, without limitation, warranties or merchantability and/or fitness for a particular purpose with respect to the equipment.

WARNING: MISUSE OF THIS EQUIPMENT CAN RESULT IN SEVERE INJURY OR DEATH. BUYER ASSUMES ALL LIABILITY IN USAGE OF EQUIPMENT.

COMPONENT OVERVIEW

ALPHAFIT

CORE CABLE CAGE PART LIST:

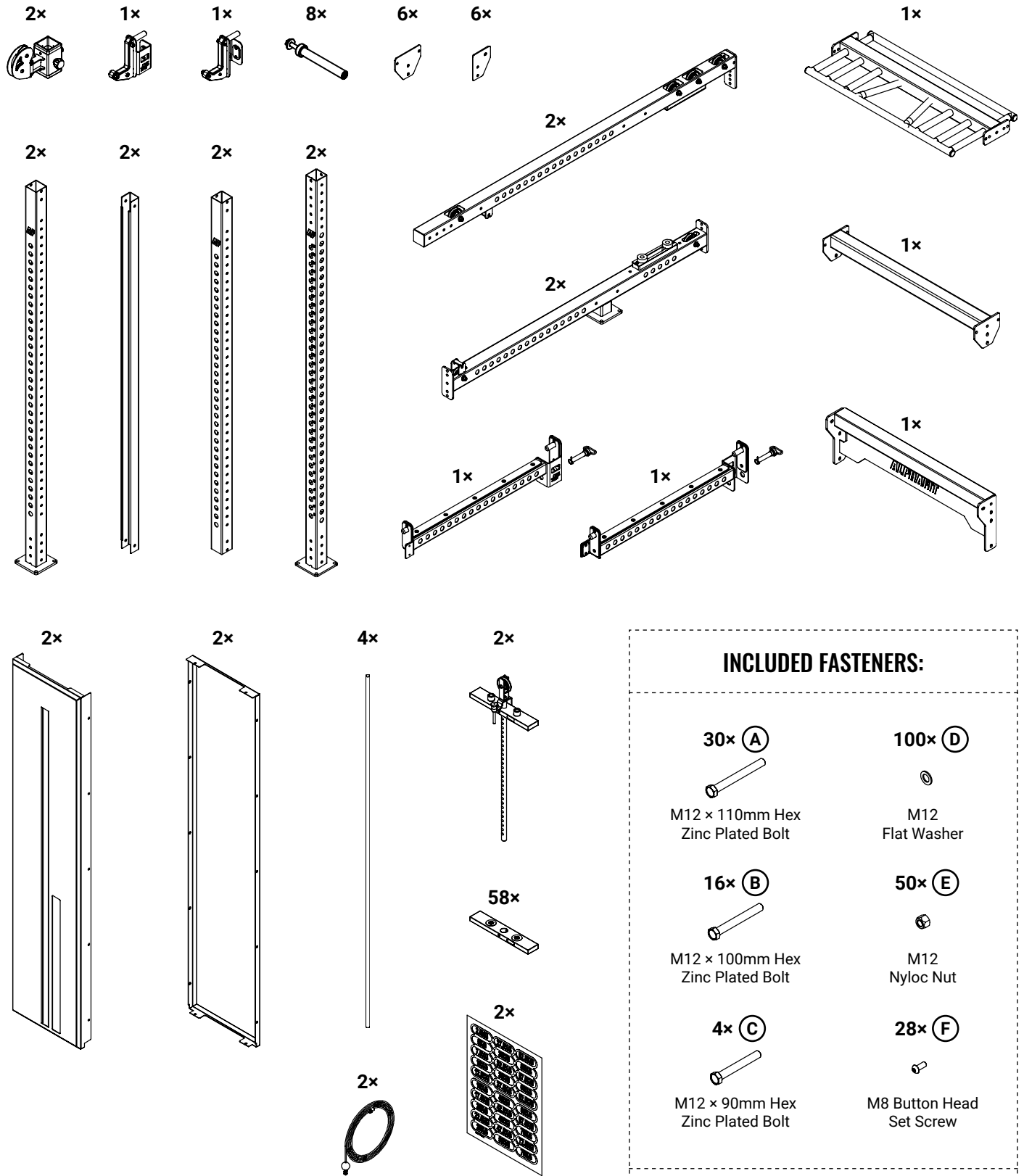

Read this entire guide before attempting to build or use this machine. This guide contains step by step instructions for proper assembly. **AlphaFit recommends a minimum of two (2) people to assemble the Core Cable Cage.**

Use the parts list included in this guide to verify that all parts are accounted for before assembly. If any parts are missing, contact AlphaFit on 1300 257 428 or admin@alphafit.com.au.

INCLUDED FASTENERS:

30x (A)



M12 x 110mm Hex Zinc Plated Bolt

100x (D)



M12 Flat Washer

16x (B)



M12 x 100mm Hex Zinc Plated Bolt

50x (E)



M12 Nyloc Nut

4x (C)



M12 x 90mm Hex Zinc Plated Bolt

28x (F)



M8 Button Head Set Screw

REQUIRED TOOLS:

- 19mm Socket & Socket Spanner
- 36mm Socket (or Adjustable Wrench)
- 5mm Hex Key

STEP 1: BUILD CAGE FRAME

Assemble trolley on front uprights. Pull out pin and slide trolley onto upright (large numbering on side face). Repeat for both front uprights. Construct cage frame as illustrated below. Letters denote appropriate fasteners.

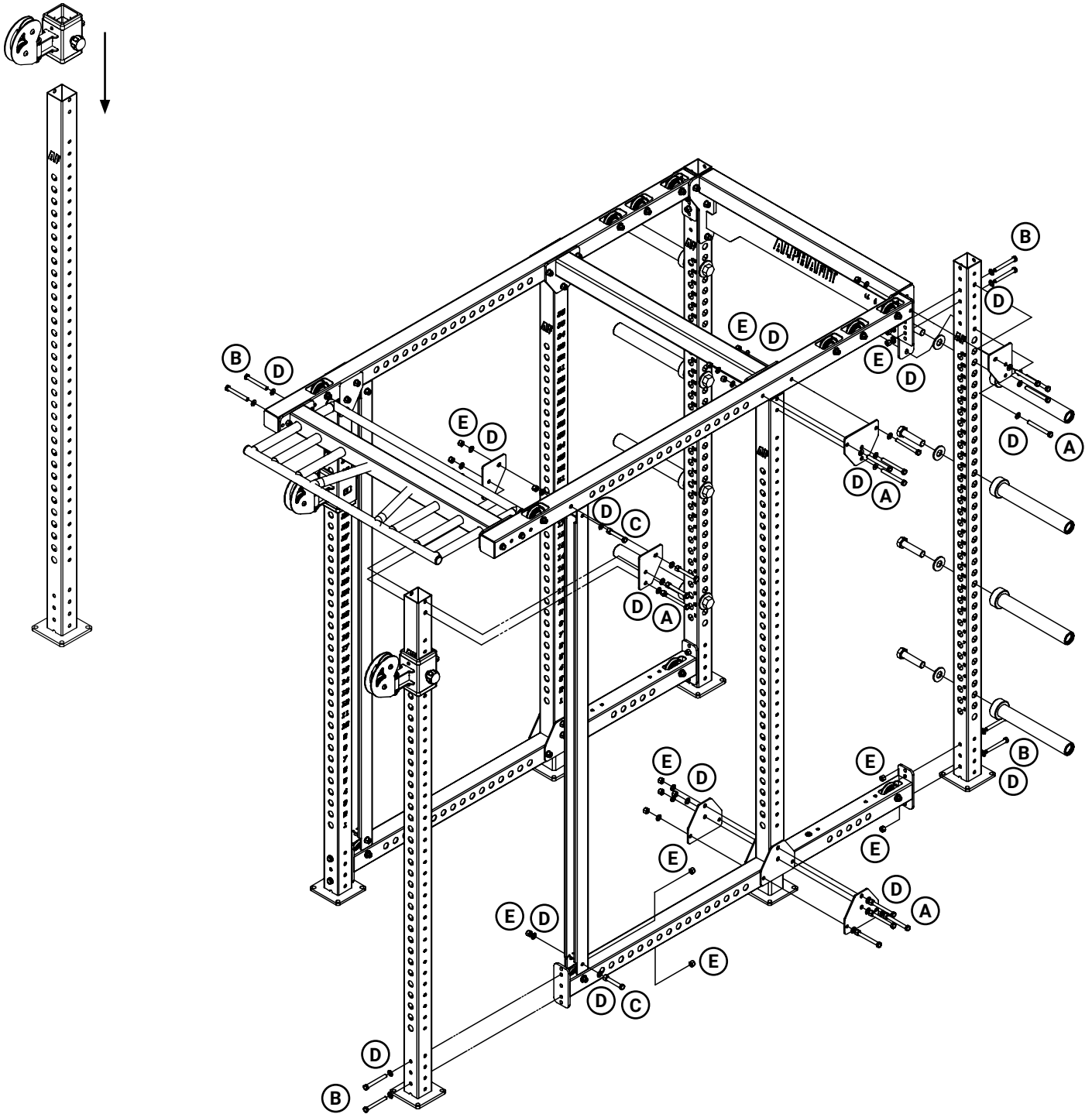

STEP 2A: INSTALL WEIGHT STACK RODS

Remove top rod holding block and cover plate.
Install rods and bump stops into bottom rod holding block as shown.

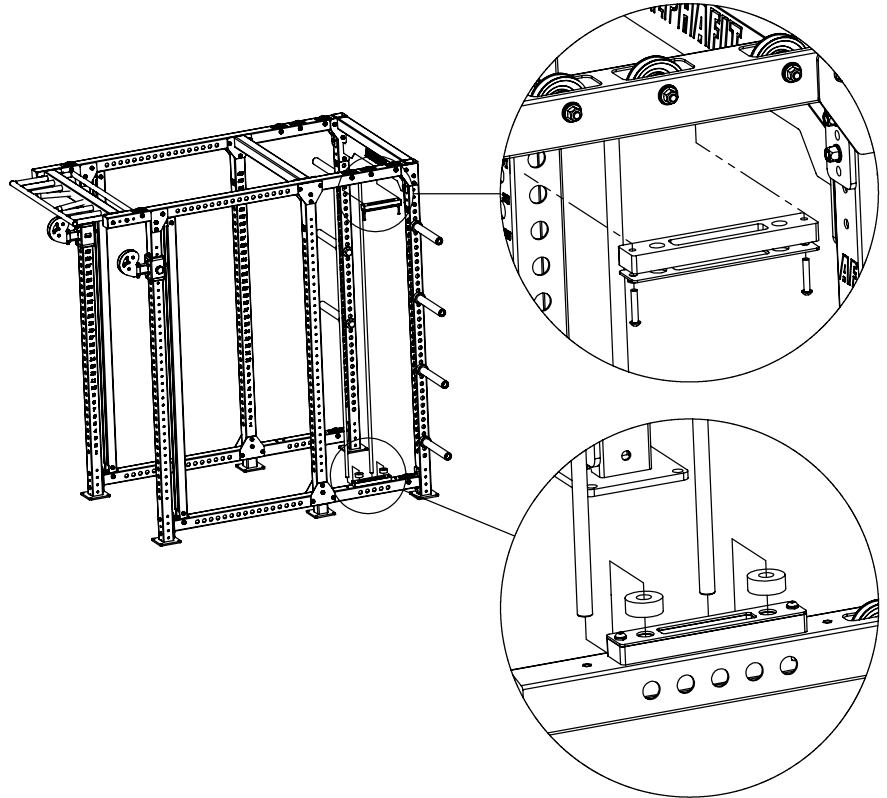

STEP 2B: INSTALL WEIGHT PLATES

Carefully tilt out weight stack rods.
Install 29 weight plates, one at a time,
taking care that orientation is as shown
(weight label to the right).

DO NOT drop weight plates.
DO NOT lean on or bump the weight
stack rods.

Install the top plate assembly, inserting
the middle rod through the centre holes
of the weight plate stack.

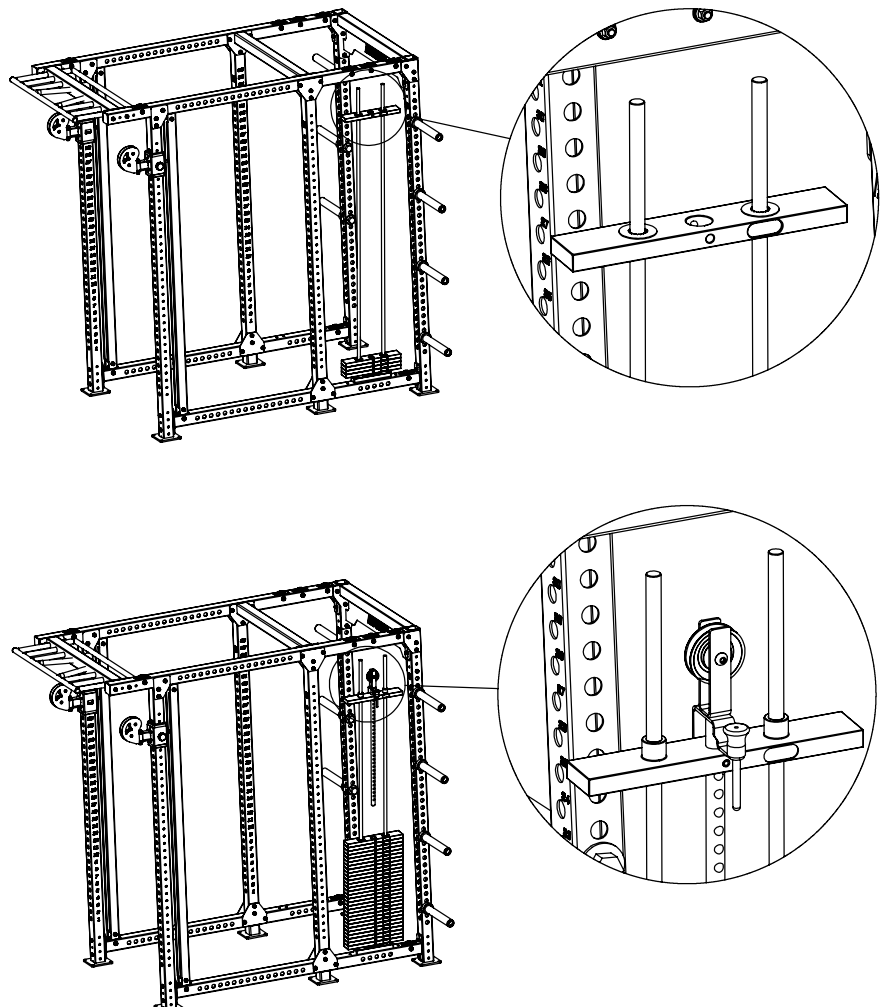

STEP 2C: SECURE WEIGHT STACK RODS

Reinstall stainless steel cover plate and rod holding block. Reinstall fasteners into underside of top frame as shown. Install weight stack labels onto weight plates with 2.5kg on the top plate down to 75kg on the bottom plate.

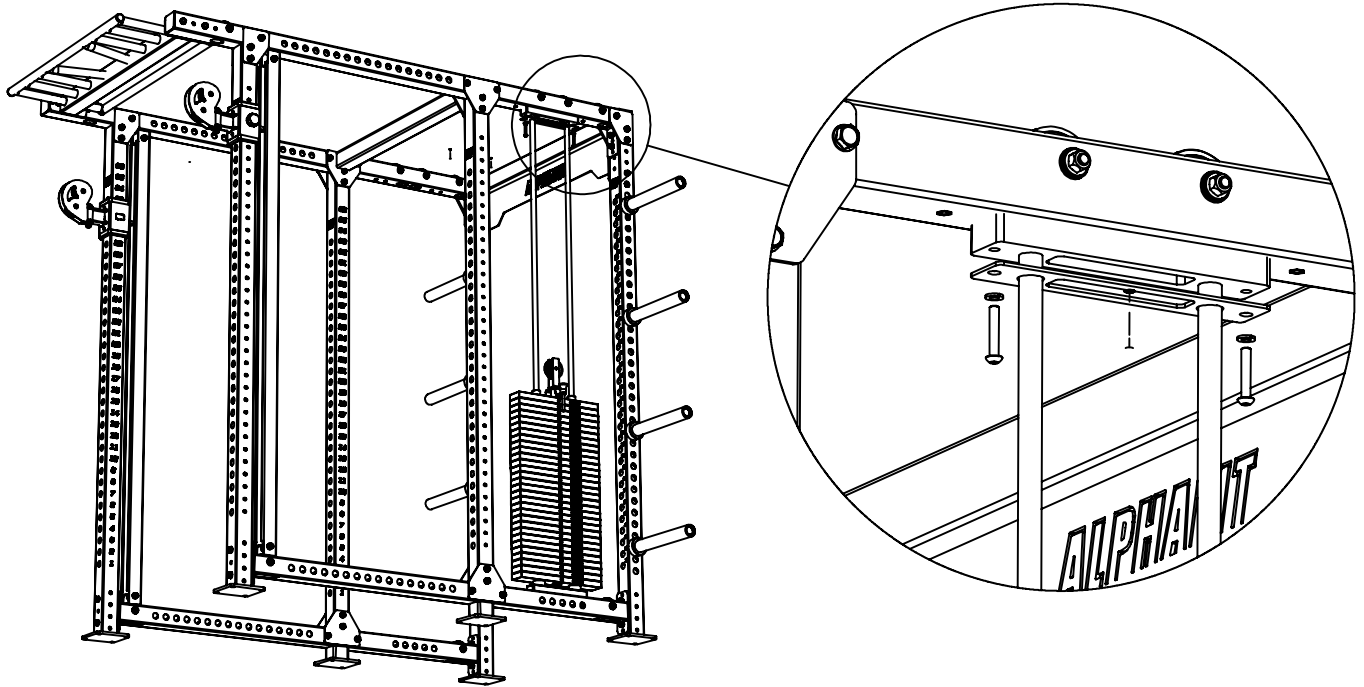

STEP 2D: ROUTE CABLE

Remove all fittings from cable attachment end, leaving adjustment bolt attached to the opposite cable end. Install bolt into underside of trolley, then start routing the cable from the trolley end through the pulleys as shown. Once the cable is threaded reinstall fittings on cable attachment end. Tighten cable as required using adjustment bolt. Ensure top plate is not lifting when properly tensioned.

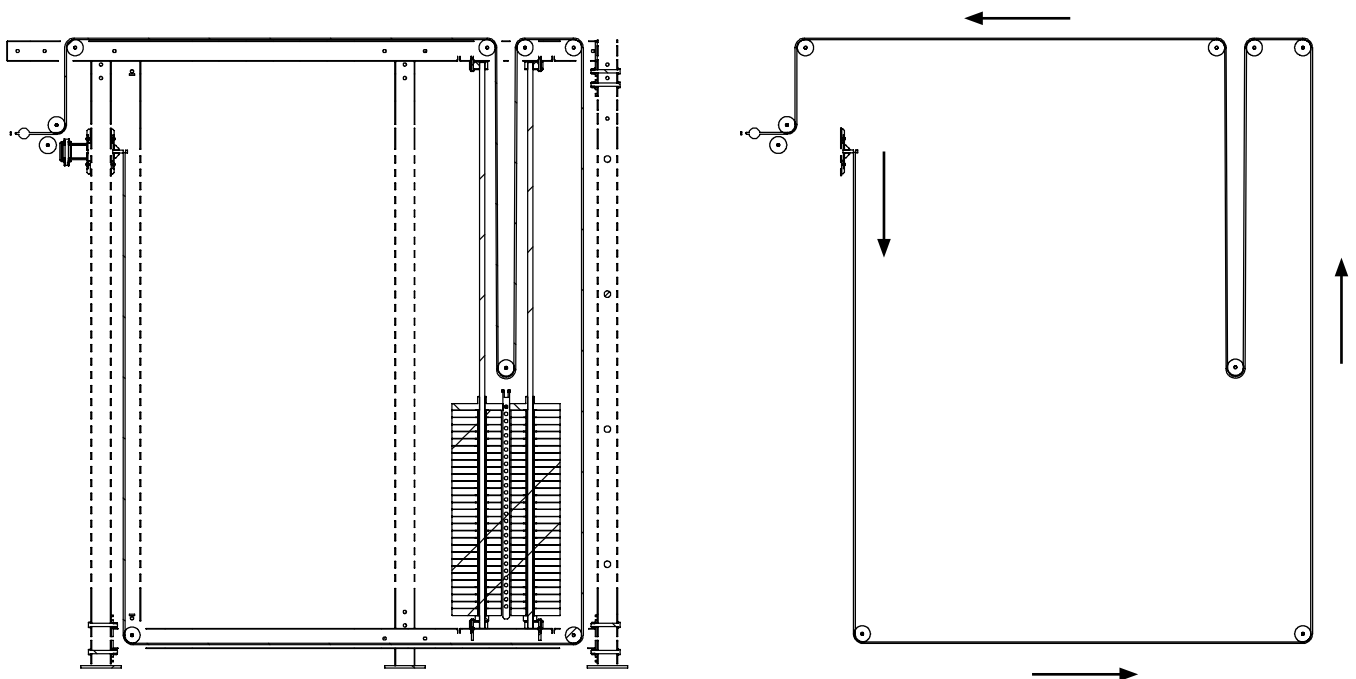

STEP 2E: ATTACH COVERS

Install rear cover and attach at top and bottom with fastener 'F' on either side of weight stack rods as shown. Install front cover onto rear cover using fastener 'F' along both sides.

Repeat steps 2A - 2E to assemble second weight stack.

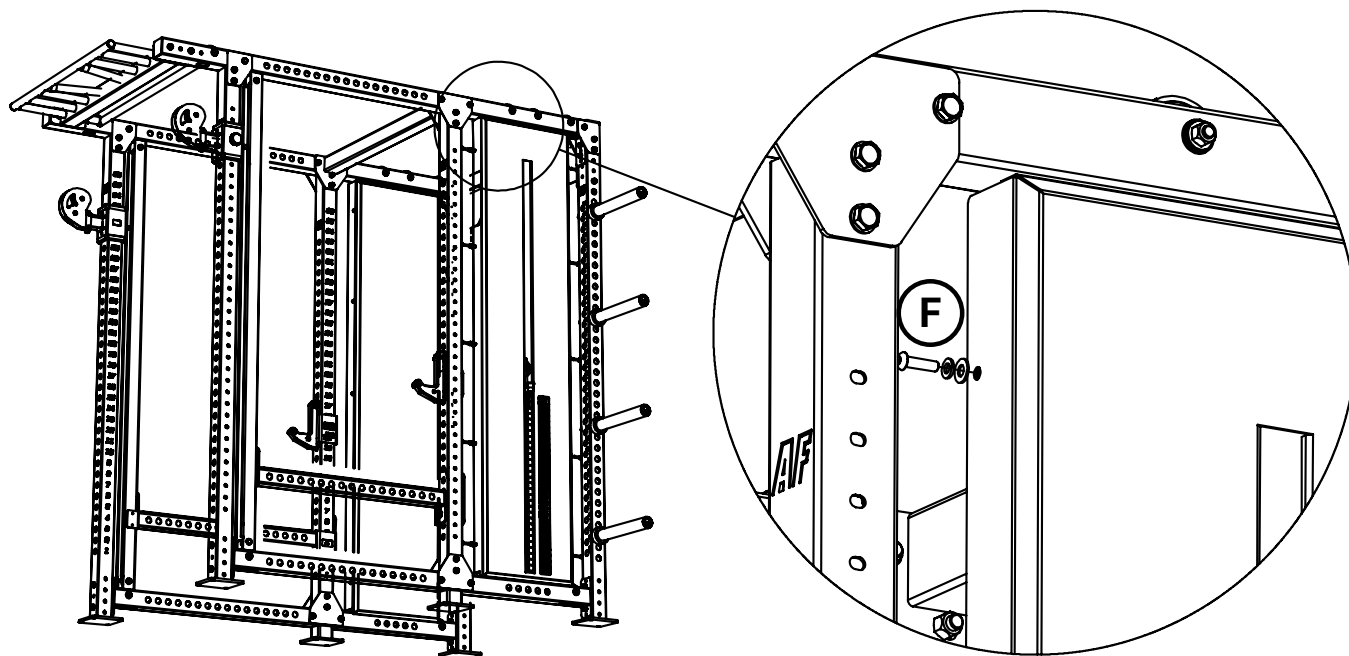
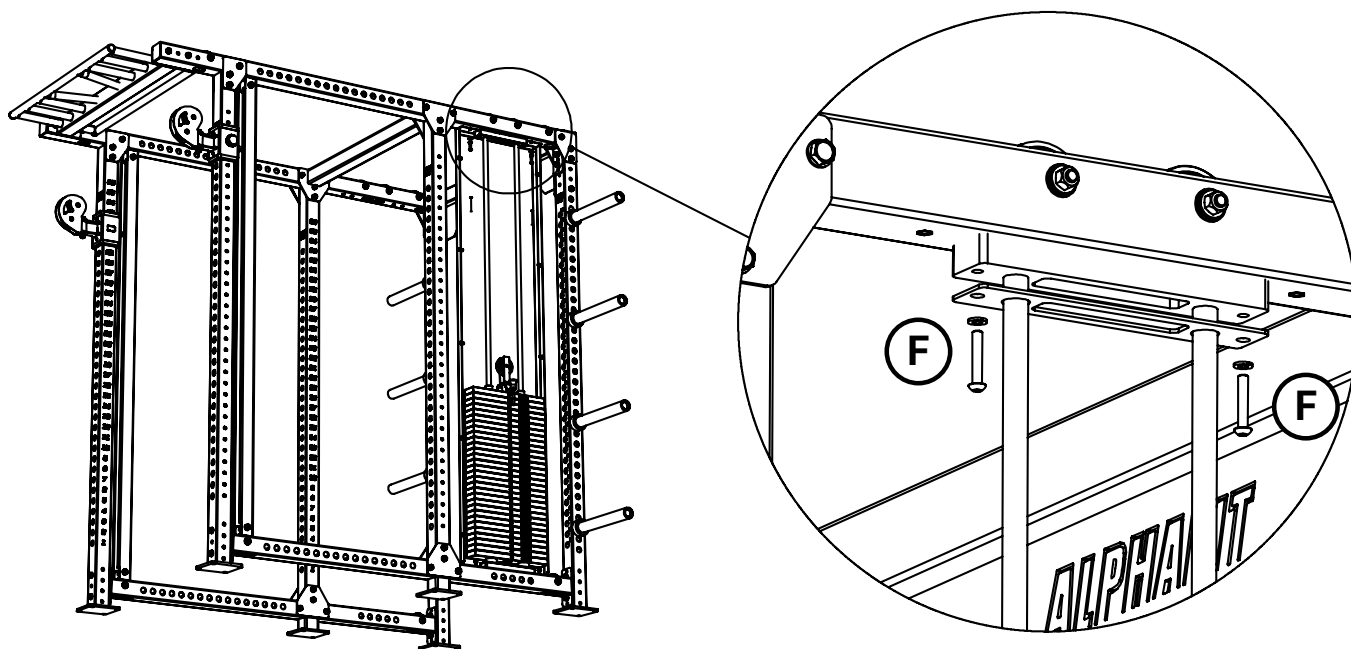

3 | INSTALL ATTACHMENTS

ALPHAFIT

STEP 3: ADD J HOOKS & SPOTTING RAILS

Install attachments by aligning on uprights using the laser cut numbers.

