

ALPHAFIT®

CORE LAT PULL LOW ROW TOWER



1 | THOUGHTFULLY DESIGNED WITH FLOOR SPACE IN MIND

With a footprint of less than three gym tiles, the Core Lat Pull Low Row Tower has been designed with the importance of floor space in mind. The fold-away foot pegs and knee pad guarantees a clear work area with no interference between Lat Pulldown and Seated Row machine settings. Seamlessly retract these features into their stowed positions to transition between workouts.

3 | NO MORE CRAMPING WITH OUR ADJUSTABLE KNEE SUPPORT

You no longer need to worry about being stuck between uncomfortable knee pad settings with AlphaFit's adjustable pull-pin. Simply guide the knee support down to your desired height for the perfect fit and no more cramps or being up on your toes.

5 | DESIGNED, ENGINEERED AND TESTED WITH SAFETY IN MIND

The Core Lat Pull Low Row Tower is industry-leading in guarding and safety with a fully enclosed weight stack. Intentionally designed with floor space, knee support and extendable seating in mind, AlphaFit's Core Lat Pull Low Row is fit for purpose and ready to take your training experience to the next level.

2 | DESIGNED WITH A PATENT PENDING EXTENDABLE SEAT

AlphaFit has designed the first extendable seat (patent pending) for a Lat Pull Low Row machine. Unlike other units in the market, there is no need to sit on the floor now that our adjustable bench has entered the game. The bench can be folded back after each use to avoid any interruption to other movements. Adjust the equipment to fit your purpose and workout with ease.

4 | THE HEAVIEST PIN LOADED STACK ON THE MARKET

AlphaFit's Core Lat Pull Low Row Tower offers the heaviest pin loaded stack on the market, boasting an impressive 150kg of weight plates. Clearly labelled, the 5kg increments provide the finest weight adjustment to allow for progressive overload and the ultimate performance.

6 | PROUDLY MADE IN AUSTRALIA, CUSTOMISE TO YOUR REQUIREMENTS

The Core Lat Pull Low Row Tower is 100% Australian made, allowing us to offer an unbeatable level of customisation including colour, branding and accessories. Train your way with market-leading equipment that's adapted to your requirements and customise your gym layout with sleek, functional equipment.

Standard model pictured - Core Lat Pull Low Row Tower in Charcoal Grey. Custom configurations and colours available. Contact your sales representative for more information.



Learn more at alphafit.com.au/core-lat-pull-low-row-tower

ALPHAFIT®



UNLIKE ANY OTHER UNIT ON THE MARKET, WITH AN ADJUSTABLE BENCH AND KNEE SUPPORT, THIS PRODUCT HAS BEEN DESIGNED WITH COMFORTABILITY AND PRACTICALITY IN MIND. PROUDLY DESIGNED AND MANUFACTURED IN AUSTRALIA, THIS MACHINE IS FIT FOR PURPOSE.



CORE LAT PULL LOW ROW TOWER SPECIFICATIONS

Product Dimensions (L x W x H): 1650mm (Lat Pull) 2155mm (Seated Row) x 300mm x 2340mm
Product Weight: 320kg
Warranty: 'Built Not Bought' warranty
Standard Colour Options: Choose from 13 colours

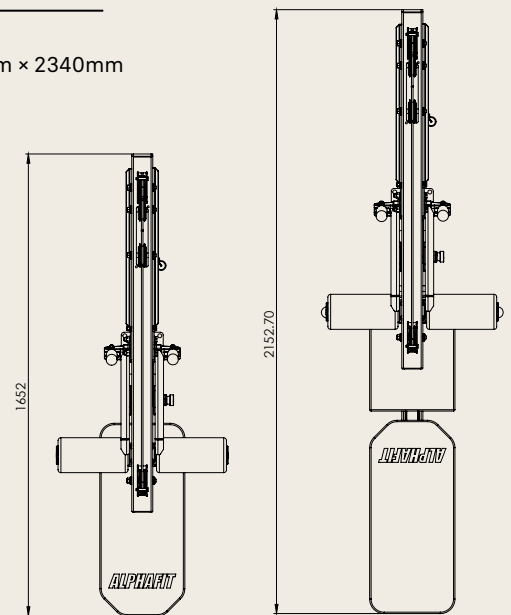
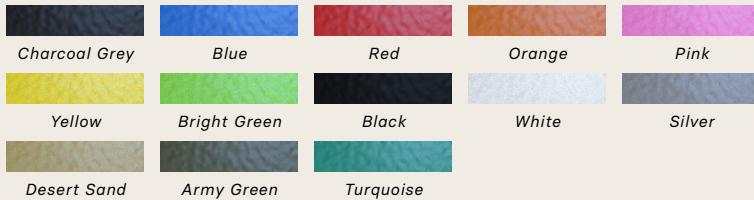

Learn more at alphafit.com.au/core-lat-pull-low-row-tower

